

AN OUTLINE GUIDE TO THE ARTICLE 4(2) DIRECTION IN THE LOCKINGTON CONSERVATION AREA



Post Office Farmhouse, Main Street, Lockington

INTRODUCTION

Under the provisions of the Town and Country Planning (General Permitted Development) Order 1995 an Article 4(2) Direction is in force on many unlisted pre War built properties in the Lockington Conservation Area (as identified on the map and table included in this guide). This Direction has introduced further planning controls in addition to those that already exist in all the District Councils Conservation Areas (which themselves are detailed in the guidance note 'Conservation Areas : An Outline Guide') and means that the submission of an application for planning permission to the District Council is necessary for a wide range of alterations to the residential properties affected. The individual owners/tenants of the properties affected have been formally notified of the serving of the Article 4(2) Direction and the existence of the Direction is revealed as a land charge in the local authority 'search' when any property changes ownership.

The District Councils overall aim in serving the Article 4(2) Direction is to secure the retention of traditional materials and architectural details to unlisted dwellings which make a significant contribution to the special character and appearance of the Lockington Conservation Area. The properties, many of which were built for the Lockington Estate, retain traditional roof coverings (Welsh slate/clay plain tiles), doors (panelled/ledged and braced), window units (sliding sashes/opening casements) and fine chimney stacks.

This guide aims to fulfil two key roles. Firstly, it is intended to indicate which works may or may not necessitate the submission of an application for planning permission to the District Council. Secondly, it aims to help householders balance their future intentions with the District Councils aim to preserve and enhance the character of the Lockington Conservation Area. It should be emphasised that the Conservation Area designation and the associated Article 4(2) Direction are not intended to stifle personal taste and imagination. Successful and sympathetic repairs and improvements can add value to a property.

**TABLE : THE PROPERTIES THE SUBJECT OF THE ARTICLE 4(2) DIRECTION IN THE
LOCKINGTON CONSERVATION AREA**

3	Main Street
5	Main Street
7	Main Street
13	Main Street
15	Main Street
17	Main Street
19	Main Street
21	Main Street
25	Main Street
27	Main Street
29	Main Street
37	Main Street
39	Main Street
2	Main Street
4	Main Street
6	Main Street
Church Cottage, Main Street	
5	Church Lane
2	Church Street
4	Church Street
6	Church Street
8	Church Street
10	Church Street
12	Church Street

WINDOW UNITS

Windows are often the most noticeable feature to the façade of a property and changing window units is often the easiest way to destroy the architectural composition of an historic building. If a property retains original window units it is well worth having them inspected by a competent conservation joiner to assess whether they can be repaired. Indeed, the repair of existing windows is often cheaper than replacement.

There are few instances where timber window units are decayed beyond repair. Often a timber window unit will be condemned as irreparable because the sill and the lower part of the unit are decayed. In many cases, however, these elements can be replaced within the otherwise sound window. Replacement sections can be satisfactorily pieced into existing windows by a competent joiner. Repaired and overhauled, with the addition of draught proofing systems, windows can perform as good as new.

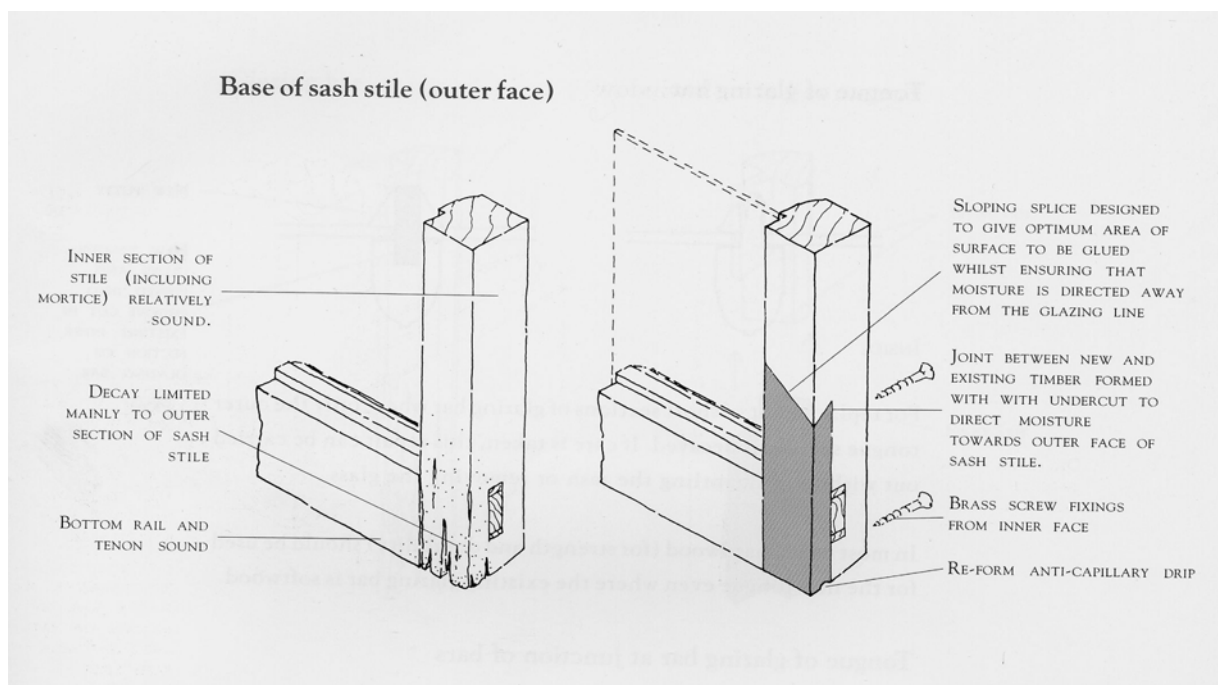

Illustration from SPAB Technical Pamphlet No 13, 'The Repair of Wood Windows'.

Repairs to existing windows do not normally require an application for planning permission. Should an application be made to remove original window units the District Council will expect that it is demonstrated that the existing windows are beyond reasonable repair.

Secondary double glazing represents an excellent way of cutting down noise and heat loss whilst retaining original window units. Fitted internally, it can have little effect on the external appearance of the building. The installation of secondary double glazing does not normally require an application for planning permission.

Where existing window units can not be repaired, new timber units can be made to match the originals. Window units should normally be painted with a white or off white paint finish. Stain is not an appropriate finish. New window units should be recessed in the opening to the same depth as original units as units placed flush with the external wall can be damaging to the appearance of the property and will expose the window unit to increased weathering.

An application for planning permission for the insertion of pvcU or stained hardwood window units will not normally be supported by the District Council.

REPLACING REPLACEMENT WINDOW UNITS ?

Modern replacement windows, although often less than 30 years old, may have decayed beyond repair, whilst original window units may have survived in spite of poor maintenance. Should householders wish to replace existing modern windows encouragement will be given to adopt a style and material more in keeping with traditional styles.

An application for planning permission is usually required for replacement windows and is more likely to be granted for timber window units which are either copies of original units or which generally reflect the design and proportions of the originals.

DOOR UNITS

Much of the advice given in this leaflet on window units is also applicable to door units. Original timber doors should be repaired where possible. Where replacement is necessary, sufficient evidence often survives to discover what many original door units would have been like. The use of similar designs to the originals will be encouraged by the District Council.

An application for planning permission for the insertion of pvcU or stained hardwood door units will not normally be supported by the District Council.

ROOFS

Changing the roof material on one property can significantly affect the appearance of the Conservation Area. It is particularly intrusive where a property is either semi-detached or forms part of a row of cottages. It is therefore important that the existing plain clay tile/slate roofs are retained.

Should a householder wish to change the material covering a roof then an application for planning permission will normally be required.

The work may also require approval under the Building Regulations. Existing roof structures may be incapable of withstanding the weight of another roofing material and may necessitate the carrying out of expensive strengthening works to the structure.

The re-laying of the existing plain tiles/slates or the use of identical new or reclaimed materials will not normally require an application for planning permission.

New or reclaimed slates should be the same colour, size and thickness as existing.

Slipped tiles/slates are often caused by rusty iron nails. The materials themselves are often suitable for reuse and can be carefully stripped from the roof, safely stored and then re-fixed using non-ferrous nails.

Householders should not be tempted to cover an existing slate roof with a bituminous coating to try and prolong its life. The application of such a material, rather than delaying re-roofing, can actually accelerate decay. An untreated slate roof is able to move with variations in temperature but once coated the inflexible skin prevents this movement. Extremes of temperature can cause hairline cracks to form into which water is drawn. Once coated the slates cannot be reused and the added expense is thus incurred of purchasing a complete new set of slates.

CHIMNEYS

Many properties in the Conservation Area have attractively detailed brick chimney stacks. These make a considerable contribution to the roofscape within the settlement.

Any alterations to a chimney stack including rebuilding or removal will require an application for planning permission.

If a chimney is redundant the pots should not be removed nor the height of the stack reduced.

PAINTING

An application for planning permission is not required to repaint door or window units in the same or similar colours to those existing. Should a change of colour be proposed an application for planning permission will normally be necessary.

BRICKWORK REPAIRS, RENDERING AND CLADDING

Where brickwork has deteriorated as a result of weathering it is beneficial to try to repair it rather than covering it with paint, render or stone cladding. Such works may hide the problem in the short term but it will not make it go away.

Not only do such finishes make a property appear out of character, disrupting the street scene and possibly undermining the appearance of neighbouring houses, but they can also damage a property causing water penetration and speeding up decay. Rendering is prone to cracking.

If a few bricks are damaged it is often possible to carefully take them out, clean them and turn them around for reinsertion. Otherwise matching reclaimed or new brickwork should be used in repair works.

An application for planning permission is required to apply paint, render or cladding to external elevations of properties. District Council will discourage the treatment of properties in this way.

POINTING AND RE-POINTING WORKS

To avoid causing long term damage to brickwork and stonework the mortar used in pointing/re-pointing should always be softer than the brick/stonework. This is best achieved by using a lime based mortar rather than a sand and cement based mix. In terms of pointing methods the use of ribbon pointing and 'bucket handle' pointing should be avoided. Further detailed guidance on pointing/re-pointing is contained in a advice note which can be obtained from the Planning and Environment Division.

RAINWATER GOODS

Surviving original cast iron downpipes and guttering can often be repaired. If replacement is necessary cast iron is the most suitable material being traditional, hard wearing and attractive. Sometimes cast aluminium can be used; pre-finished systems require no initial painting and are light and easy to fix. The use of rise and fall brackets to cast iron or cast aluminium guttering is normally appropriate.

Replacement rainwater goods should always be of the same dimensions and profile as the originals to ensure that performance and appearance are not reduced. A black paint finish is normally the most appropriate. PvcU rainwater goods should not be used as replacements to cast iron or cast aluminium goods as they have a poor appearance and require large numbers of support brackets whilst still often sagging between brackets in hot weather.

An application for planning permission is normally required for new/replacement rainwater goods. The Council will discourage the use of pvcU rainwater goods as replacements to cast iron or cast aluminium goods.

PORCHES AND DOOR CANOPIES

Original porches/door canopies are particularly important to the architectural composition of some properties. They represent an important aspect of the street scene and contain such fine architectural detailing that their preservation is important to the Conservation Area. Brickwork supports should not be painted or rendered whilst timber support brackets are usually painted. The general advice given on roofs is equally applicable to porch roofs.

An application for planning permission is usually required to make any alteration to existing porches or to erect a new porch.

EXTENDING A DWELLING

An application for planning permission will be required in many instances for the erection of extensions, including porches and conservatories. The design of an extension is more likely to be acceptable to the District Council if the guidelines below are followed.

Extensions to houses should adhere to good overall design standards and should respect the scale and character of the existing and surrounding properties. It is particularly important that extensions are not over large or dominant. Certain properties or even particular elevations may not be suitable for an extension of any type. A small extension such as a porch or bay window, when not appropriate to the original building type, can in some instances detract from the character of a Conservation Area as much as a larger extension. Flat roofed extensions should normally be avoided.

In a Conservation Area materials and precise design details are also important. The following items are relevant considerations when designing extensions to most properties:-

1. Bricks should match the size, colour and texture of those to the original property.
2. Natural Welsh slate or clay plain tiles should be used for roofs. These should be laid to a pitch of at least 35 degrees.
3. Ridge tiles (where applicable) should match those to the original roof of the property.
4. The design of window units, their spacing, materials and opening methods should reflect the original window type to the property.
5. Window units should be of timber construction with a white or off-white paint finish.
6. Design details should reflect those to the existing property and may include stone sills and lintels, shallow segmental brick arches, string and dentil courses or other brickwork detailing as appropriate.
7. The use of black cast iron or black cast aluminium rainwater goods is appropriate.
8. Original detailing of architectural interest should not be lost as a result of the extension of a property.

BASIC HOUSEHOLD REPAIRS

The majority of basic household repairs do not require an application for planning permission as long as they do not involve material alterations to the external elevations.

THE SUBMISSION OF A PLANNING APPLICATION

The relevant application forms for the submission of development proposals are available from the Planning and Environment Division (and are the same as those for other planning applications). The application forms should be completed and returned with four copies of the necessary plans (all to a metric scale) detailing the location of the application property along with the precise details of works being proposed. No fee is payable for applications that are necessary as a direct result of the introduction of the Article 4(2) Direction.

FURTHER INFORMATION

The leaflet is to be used for guidance only by owners, tenants and prospective purchasers of the properties the subject of the Article 4(2) Direction and does not purport to represent an accurate statement of planning law. Prior to the commencement of any works owners/tenants of properties are recommended to seek advice from the Planning and Environment Division as alterations undertaken without the necessary planning permission may subsequently have to be removed and/or reinstated. It is also emphasised that this guide relates only to the additional planning controls introduced by the Article 4(2) Direction and should therefore be read in conjunction with the leaflet 'Conservation Areas : An Outline Guide' which is available from the Planning and Environment Division. Separate controls relate to listed buildings for which a guide is also available from the Planning and Environment Division. Building regulations consent may be required for some works.

STATUS OF THIS ADVICE NOTE

On 18 September 2001 this advice note was adopted by the District Council's Executive Board as supplementary planning guidance to the policies of the deposited North West Leicestershire Local Plan (as proposed to be modified). The advice note whilst not having the same status as an adopted plan policy may be taken into account as a material consideration in the determination of planning applications.

OTHER RELEVANT SUPPLEMENTARY PLANNING GUIDANCE

In April 2001 the District Council's Executive Board adopted the Lockington Conservation Area Appraisal/Study document as supplementary planning guidance to the policies of the deposited North West Leicestershire Local Plan (as proposed to be modified). The Appraisal/Study document aims to fulfil a number of key roles. The Appraisal outlines the historical development of Lockington and defines the special interest, character and appearance of the built and natural environment within and surrounding the Conservation Area. The Study identifies future opportunities for the preservation and enhancement of the Area. The Appraisal/Study document can viewed at, or purchased from, the Planning and Environment Division at the Council Offices during normal weekday office hours.

PLANNING AND ENVIRONMENT DIVISION

NORTH WEST LEICESTERSHIRE DISTRICT COUNCIL

COUNCIL OFFICES

COALVILLE

LEICESTERSHIRE, LE67 3FJ

TELEPHONE : (01530) 454545

September 2001